

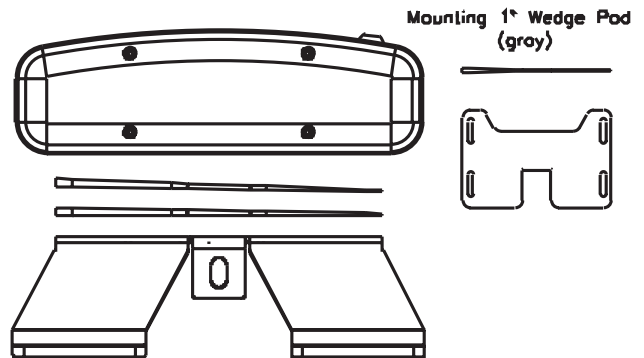

MOUNTING INSTRUCTIONS APPLICATIONS AND CONFIGURATIONS

IMPALA PAD CONFIGURATION

1. When mounting a Millennium to a Chevy Impala, two (2) of the gray 1" Wedge Pads need to be used to level the light bar.
2. Stack both 1" Wedge Pads so that the thicker part of the Wedge faces the leading edge of the light bar (reference the illustration for driver-side placement)



CROWN VICTORIA PAD CONFIGURATION

1. When mounting a Millennium to a Ford Crown Victoria, one (1) of the gray 1" Wedge Pads needs to be used to level the light bar.
2. Place the 1" Wedge Pad so that the thicker part of the Wedge faces the leading edge of the light bar (reference the illustration for driver-side placement).

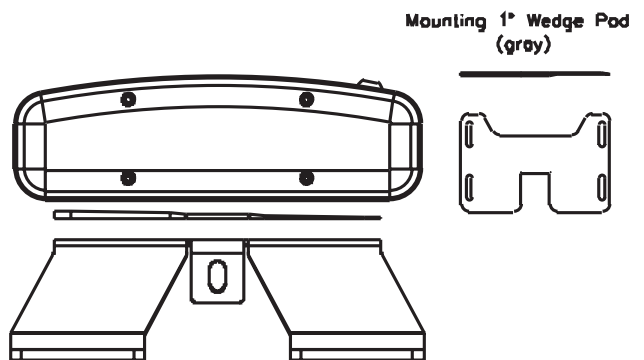

FLAT SURFACE PAD CONFIGURATION

1. When mounting a Millennium to a level surface, one (1) of the black Flat Pads needs to be used.
2. Place the Flat Pad so that the profile of the pad and bracket match (reference the illustration for driver-side placement).

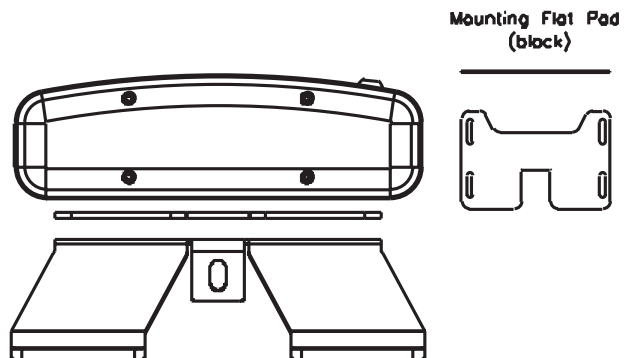



MOUNTING INSTRUCTIONS

TO INSTALL MOUNTING BRACKET:

1. Set light bar upside down on a non-abrasive surface to assess chassis inserts.
2. Using the provided nuts, bolts, washers and gaskets, install the bracket onto the light bar in the desired location within the confines of bracket slots as shown.
3. Once positioned, using a 5/32" hex key, tighten the eight (8) bolts to secure the bracket to the chassis.

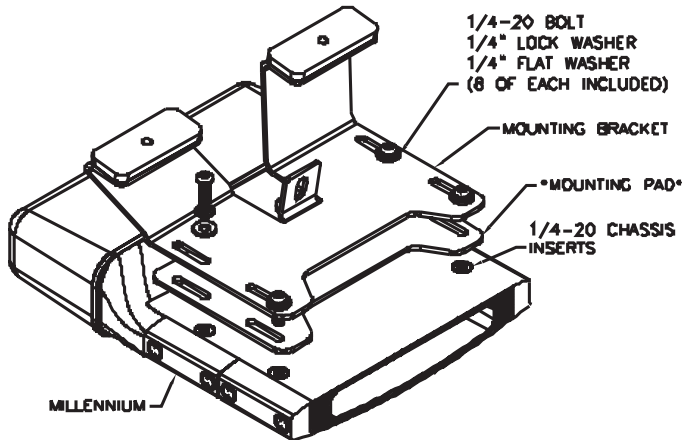

Before installing Mounting Pad, Reference Bottom Illustration For Pad Selection

INSTALLATION

1. Position light atop the vehicle making sure that it is centered left to right.
2. Set the tension mount on the car orientated as shown, align tension bolt hole (A) with the hole in the mounting bracket tension tab. Mark the position of the two (2) #10 self-tapping holes (B).
3. For ease of insertion, predrill the two (2) premarked #10 screw holes using a 5/32" drill.
4. Install tension mounts using the four (4) provided #10 self-tapping screws.
5. Secure the Millennium, with mounting bracket attached, using the tension bolt and the 5/16" nut and washers.

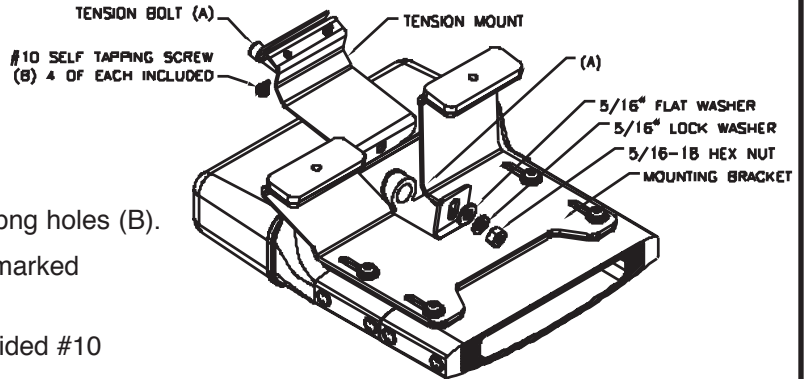

Tension Mount May Change Depending On Vehicle Make and Model

SELECTION OF PROVIDED SPACERS

1. The (black) Mounting Pad should only be used if there is no need to increase the angle of elevation of the leading edge. This pad is designed to reduce vibration when mounting on a surface which is already parallel with the road.
2. The (gray) Mounting Wedge should be used in place of the (black) Mounting Pad if the mounting surface is not parallel with the road and the leading edge angle of elevation needs to be increased.
3. Reference top illustration for proper placement of required pad.
4. See illustrations on opposite side for sample pad configurations.

